

**DO NOT OPEN THIS TEST BOOKLET UNTIL YOU ARE ASKED TO DO SO**

**T.B.C. : Q-GUG-K-NFB**

**Test Booklet Series**

**Serial No 036741**

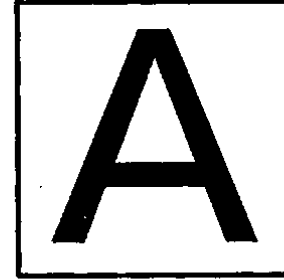

**TEST BOOKLET**

**MECHANICAL ENGINEERING**

**PAPER II**

**Time Allowed : Two Hours**

**Maximum Marks : 200**

**INSTRUCTIONS**

1. IMMEDIATELY AFTER THE COMMENCEMENT OF THE EXAMINATION, YOU SHOULD CHECK THAT THIS TEST BOOKLET DOES **NOT** HAVE ANY UNPRINTED OR TORN OR MISSING PAGES OR ITEMS ETC. IF SO, GET IT REPLACED BY A COMPLETE TEST BOOKLET.
2. ENCODE CLEARLY THE TEST BOOKLET SERIES A, B, C, OR D AS THE CASE MAY BE IN THE APPROPRIATE PLACE IN THE ANSWER SHEET.
3. You have to enter your Roll Number on the Test Booklet in the Box provided alongside. **DO NOT** write *anything else* on the Test Booklet.
4. This Test Booklet contains **120** items (questions). Each item comprises four responses (answers). You will select the response which you want to mark on the Answer Sheet. In case you feel that there is more than one correct response, mark the response which you consider the best. In any case, choose **ONLY ONE** response for each item.
5. You have to mark all your responses **ONLY** on the separate Answer Sheet provided. See directions in the Answer Sheet.
6. All items carry equal marks.
7. Before you proceed to mark in the Answer Sheet the response to various items in the Test Booklet, you have to fill in some particulars in the Answer Sheet as per instructions sent to you with your Admission Certificate.
8. After you have completed filling in all your responses on the Answer Sheet and the examination has concluded, you should hand over to the Invigilator **only the Answer Sheet**. You are permitted to take away with you the Test Booklet.
9. Sheets for rough work are appended in the Test Booklet at the end.
10. **Penalty for wrong answers :**  
THERE WILL BE PENALTY FOR WRONG ANSWERS MARKED BY A CANDIDATE IN THE OBJECTIVE TYPE QUESTION PAPERS.
  - (i) There are four alternatives for the answer to every question. For each question for which a wrong answer has been given by the candidate, **one-third (0.33)** of the marks assigned to that question will be deducted as penalty.
  - (ii) If a candidate gives more than one answer, it will be treated as a **wrong answer** even if one of the given answers happens to be correct and there will be same penalty as above to that question.
  - (iii) If a question is left blank, i.e., no answer is given by the candidate, there will be **no penalty** for that question.

**DO NOT OPEN THIS TEST BOOKLET UNTIL YOU ARE ASKED TO DO SO**

1.

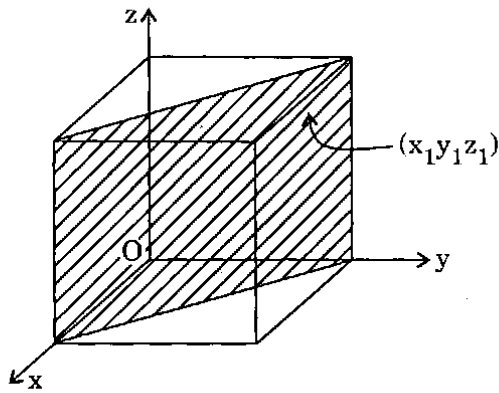

Miller indices  $(x, y, z)$  for the hatched plane in the above unit cell are represented as

- (a)  $(1\ 0\ 0)$
- (b)  $(1\ 1\ 0)$
- (c)  $(1\ 1\ 1)$
- (d)  $(1\ 0\ 1)$

2.

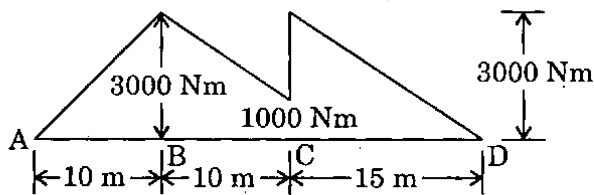
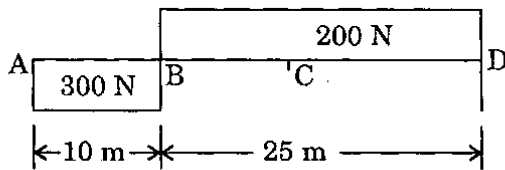

Shear force and bending moment diagrams for a beam ABCD are shown in figure. It can be concluded that

- (a) The beam has three supports
- (b) End A is fixed
- (c) A couple of 2000 Nm acts at C
- (d) A uniformly distributed load is confined to portion BC only

3.

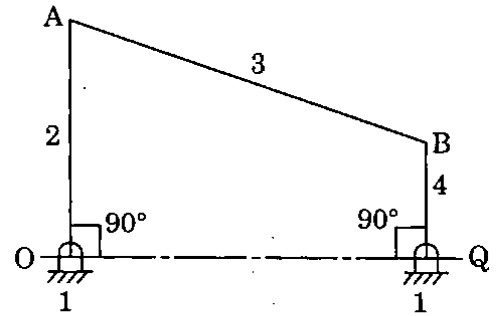

Consider the following statements with reference to the four bar mechanism as shown in the figure above :

At the instant considered,

- 1.  $\omega_2 = \omega_4$
- 2. Link 3 undergoes pure translation.
- 3. Velocity diagram is a straight line.
- 4.  $V_{A/B} = (\omega_4 - \omega_2) AB$

Which of the above statements are correct ?

- (a) 1, 2 and 3 only
- (b) 2 and 3 only
- (c) 2 and 4 only
- (d) 1, 2, 3 and 4

4.

Which one of the following is *not* a statically indeterminate structure ?

- (a)
- (b)
- (c)
- (d)

5.

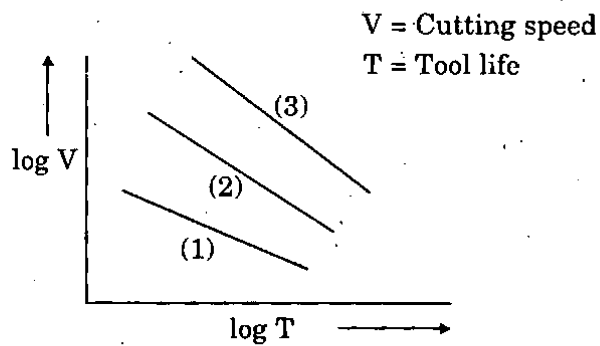

The above figure shows a typical relationship between tool life and cutting speed for different materials. Match the graphs for HSS, Carbide and Ceramic tool materials and select the correct answer using the code given below the lists :

**Code :**

	HSS	Carbide	Ceramic
(a)	1	2	3
(b)	3	2	1
(c)	1	3	2
(d)	3	1	2

6.

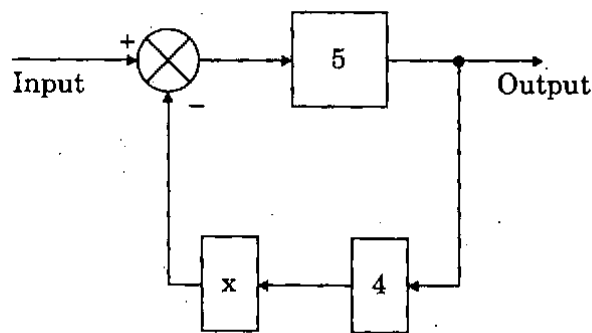

The above figure shows the block diagram of an automatic control system having bounded input. The output becomes unbounded if the value of x is

- (a) 1
- (b) - 0.25
- (c) - 0.2
- (d) 0.25

7.

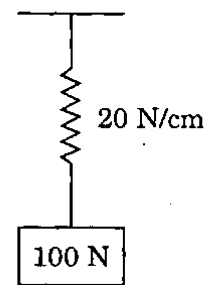

The natural frequency of the system shown in the figure above will increase when

- (a) 100 N is increased to 150 N
- (b) Stiffness of spring is reduced
- (c) Weight is reduced to 50 N and stiffness is reduced to 10 N/cm
- (d) Weight is reduced to 50 N and stiffness is increased to 40 N/cm

8.

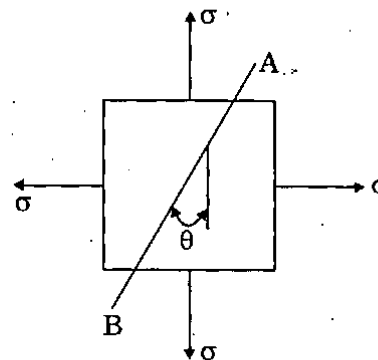

A point in two-dimensional stress state, is subjected to biaxial stress as shown in the above figure. The shear stress acting on the plane AB is

- (a) Zero
- (b)  $\sigma$
- (c)  $\sigma \cos^2 \theta$
- (d)  $\sigma \sin \theta \cdot \cos \theta$

9.

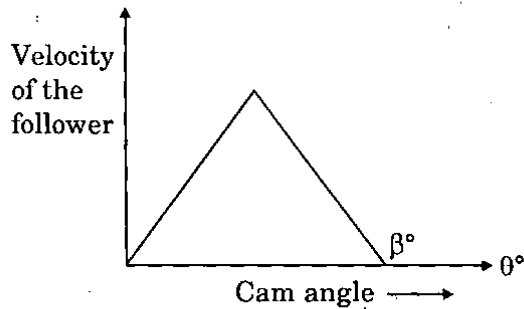

The above figure shows the required velocity profile for a follower of a cam during its rise. If the driving cam is rotating at a uniform velocity, the nature of displacement recommended for the follower is

- (a) Cycloidal
- (b) Simple harmonic
- (c) Parabolic
- (d) Uniform

10.

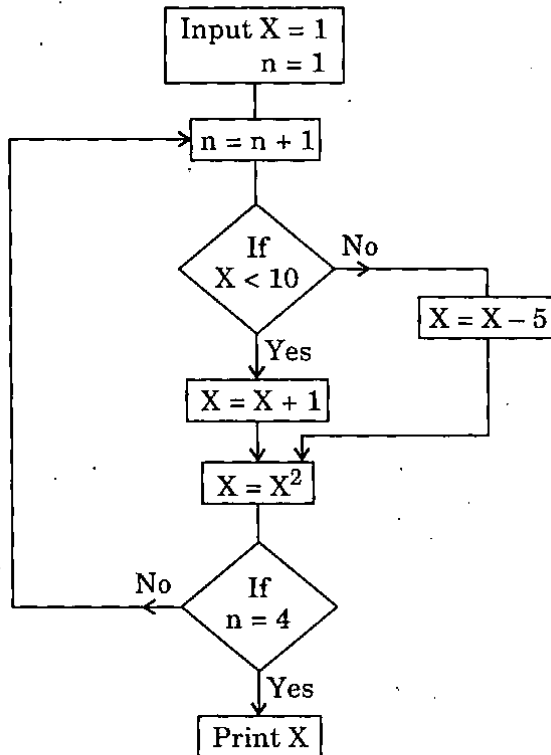

The value of X given by the programme represented by the flow chart is

- (a) 200
- (b) 400
- (c) 676
- (d) 800

11. Match List I with List II and select the correct answer using the code given below the lists :

*List I*  
(Symbols for  
direction of lay)

*List II*  
(Surface texture)

A. =

1.

B. ×

2.

C. I

3.

D. R

4.

Code :

	A	B	C	D
(a)	4	2	1	3
(b)	3	2	1	4
(c)	4	1	2	3
(d)	3	1	2	4

12. The correct statement is

- (a) Characteristic of any series of alloys cannot be found by phase diagram.
- (b) Phase diagram does not give amount of phases which are a function of composition, temperature and pressure.
- (c) The phase may be liquid or vapour with ordered crystal structure.
- (d) Phase diagram provides the information on how rapidly equilibrium is reached.

13. If,  $D$  = annual demand for a material (units per year).  
 $Q$  = quantity of material ordered at each order point (units per order).  
 $C$  = cost of carrying one unit in inventory for one year (rupees per unit per year).  
 $S$  = average cost of completing an order for a material (rupees per order).  
 $TSC$  = total annual stocking costs for a material (rupees per year).  
Then, the economic order quantity (EOQ) is
- (a)  $\sqrt{\frac{2DS}{C}}$
- (b)  $\frac{2DC}{S}$
- (c)  $\sqrt{\frac{2DC}{S}}$
- (d)  $\frac{2DS}{C}$
14. In the inventory control, if the yearly demand for a certain material is fixed, the economic order quantity gives minimum
- (a) Inventory carrying cost per year  
(b) Acquisition cost per year  
(c) Total cost per year  
(d) Number of orders per year
15. The cutting tool material required to sustain high temperature is
- (a) High carbon steel alloys  
(b) Composite of lead and steel  
(c) Cermet  
(d) Alloy of steel, zinc and tungsten
16. In CPM, the project duration can be reduced by crashing
- (a) One or more non-critical activities  
(b) One or more critical activities only  
(c) One or more dummy activities only  
(d) Activities having independent float
17. Plastic material is used for the component which requires characteristics of
- (a) Low density, machinability and high strength  
(b) Machinability, high strength and large plastic deformation  
(c) High strength, large plastic deformation and low density  
(d) Low density, machinability and large plastic deformation
18. In project scheduling, networks have an advantage over Gantt charts since networks
- (a) show start and finish of an activity clearly  
(b) show activity and activity times clearly  
(c) show inter-relationship among activities clearly  
(d) are easy to draw
19. Constituents of ceramics are oxides of different materials, which are
- (a) Cold mixed to make ceramic pellets  
(b) Ground, sintered and palleted to make ready ceramics  
(c) Ground, washed with acid, heated and cooled  
(d) Ground, sintered, palleted and after calcining cooled in oxygen
20. Consider the following properties for plastics :
1. Become hard on heating.
  2. Increasing plasticity.
  3. Ability to deform with rise in temperature.
  4. Long chain structure.
- Which of these properties for plastics are correct ?
- (a) 1, 2, 3 and 4  
(b) 3 and 4 only  
(c) 1 and 4 only  
(d) 2, 3 and 4 only

21. Which of the following is *not* the characteristic of exponential smoothing method of forecasting ?
- This represents a weighted average of the past observations.
  - All observations are assigned equal weightage.
  - If smoothing coefficient is 1 then the latest forecast would be equal to previous period actual demand.
  - The technique is not simple as compared to moving average method.
22. In exponential smoothing method of forecasting, the forecast for higher values of the smoothing constant
- will be more sensitive to forecast of the previous period
  - will be more sensitive to changing patterns in demand
  - will not be affected by the forecast of the previous period
  - will not be affected by the changing patterns in demand
23. Consider the following statements :  
The bearing characteristic number is
- Dimensionless.
  - Inversely proportional to speed.
  - Directly proportional to viscosity.
  - Independent of journal radius.
- Which of the above statements is/are correct ?
- 2 and 3 only
  - 1 and 3 only
  - 1 only
  - 1, 2, 3 and 4
24. In the moving average method of forecasting, the number of periods (AP) of data is dependent on the
- Criteria of accuracy only
  - Impulse response only
  - Noise damping only
  - Criteria of accuracy, impulse response and noise damping
25. Consider the following statements regarding composite materials :
- Material is termed as advanced composite, if fibres are directionally oriented and continuous.
  - Reinforced fibre glass products are strong and light weight.
  - Concrete is reinforced with steel rebar, the rebar becomes matrix.
  - Pearlitic steels are composite materials.
- Which of the above statements are correct ?
- 1, 2 and 3 only
  - 2, 3 and 4 only
  - 1, 2 and 4 only
  - 1, 2, 3 and 4
26. Some high speed steels have cobalt (Co) added to them in amounts ranging from 2% to 15%, since this element improves the
- Cutting efficiency, especially at high temperature
  - Depth hardening ability of the HSS tool
  - Red hardness of the HSS tool
  - Grain structure of the HSS tool
27. A dealer for washing machines forecasts the demand at the rate of 600 units per month, for the next four months. The actual demand is found to be 500, 680, 800 and 900 units. The mean absolute deviation (MAD) and the BIAS are found to be
- 170 and -120
  - 120 and 170
  - 340 and -240
  - 240 and 340

28. Value engineering is necessary to be used when following symptoms are indicated :

1. New product designs are to be introduced.
2. The firm is unable to meet delivery date.
3. Rate of return on investment goes down.

Which of the above statements is/are correct ?

- (a) 1, 2 and 3
- (b) 2 only
- (c) 1 and 3 only
- (d) 2 and 3 only

29. The relationship between the shear angle  $\Phi$ , the friction angle  $\beta$  and cutting rake angle  $\alpha$  is given as

- (a)  $2\beta + \Phi - \alpha = C$
- (b)  $2\Phi + \beta - \alpha = C$
- (c)  $2\alpha + \beta - \Phi = C$
- (d)  $\Phi + 2\beta - \alpha = C$

30. Isothermal annealing is mainly used in alloy steels to improve

- (a) Machinability
- (b) Toughness
- (c) Ductility
- (d) Weldability

31. In journal bearing design, the factor  $\frac{ZN}{p}$  is called the 'Bearing characteristics number' where  $Z$  = absolute viscosity of the lubricant,  $N$  = speed of journal in rpm and  $p$  = bearing pressure on the projected bearing area. The value of  $\frac{ZN}{p}$  corresponding to the minimum amount of friction is called the bearing modulus 'K'. For hydrodynamic lubrication of the bearing,  $\frac{ZN}{p}$  should be

- (a) Larger than K
- (b) Smaller than K
- (c) Equal to K
- (d) Equal to zero

32. Consider the following statements :

Good dynamic performance is usually difficult to achieve in robots which contain a rotary base because

1. Position, speed and acceleration of the other joints cause variations in the reflected torque and moment of inertia.
2. The moment of inertia reflected at the base depends upon the weight of the object being carried.
3. The moment of inertia reflected at the base also depends upon the distance between the base axis and the manipulated object.

Which of the above statements is/are correct ?

- (a) 1, 2 and 3
- (b) 2 and 3 only
- (c) 1 only
- (d) 1 and 3 only

33. The ratio of the core of a rectangular section to the area of the rectangular section when used as a short column is

- (a)  $\frac{1}{9}$
- (b)  $\frac{1}{36}$
- (c)  $\frac{1}{18}$
- (d)  $\frac{1}{24}$

34. In relation to product flexibility and production volume achieved in computer controlled manufacturing systems, the flexible manufacturing system has

- (a) High flexibility in types of product but low volume of production
- (b) Moderate product flexibility and moderate production volume
- (c) Low product flexibility but high production volume
- (d) Extremely low product flexibility but low production volume

35. In relation to the peripheral or surface speeds of the grinding wheel and that of the workpiece in cylindrical grinding of alloy steel workpieces, the grinding wheel speed is

- (a) Less than the speed of the workpiece
- (b) Same as the speed of the workpiece
- (c) Double the speed of the workpiece
- (d) 65 to 75 times the speed of the workpiece

36. Match List I with List II and select the correct answer using the code given below the lists :

<i>List I</i> ( <i>Quenching media</i> )	<i>List II</i> ( <i>Structure produced</i> )
A. Water	1. Coarse pearlite
B. Oil	2. Martensite
C. Air	3. Very fine pearlite
D. Furnace coal	4. Fine pearlite

**Code :**

	A	B	C	D
(a)	1	3	4	2
(b)	2	3	4	1
(c)	1	4	3	2
(d)	2	4	3	1

37. Consider the following :

- 1. Water
- 2. Ice
- 3. Brine solution
- 4. Oil

Which of these is/are used as quenching media in case of Alloy steels ?

- (a) 1, 2 and 3 only
- (b) 2, 3 and 4 only
- (c) 1 and 4 only
- (d) 4 only

38. The linear programming is used for optimization problems which satisfy the following conditions :

- 1. Objective function expressed as a linear function of variables.
- 2. Resources are unlimited.
- 3. The decision variables are inter-related and non-negative.

Which of the above statements is/are correct ?

- (a) 1, 2 and 3
- (b) 2 and 3 only
- (c) 1 only
- (d) 1 and 3 only



39. Consider the following statements :

1. For the application of optimality test in case of transportation model, the number of allocations should be equal to  $m + n$ , where  $m$  is the number of rows and  $n$  is the number of columns of the matrix.
2. Transportation problem is a special case of a linear programming problem.
3. In case of assignment problem the first step is to make a square matrix by adding a dummy row or a dummy column.

Which of the above statements is/are correct ?

- (a) 1, 2 and 3
- (b) 1 and 2 only
- (c) 2 and 3 only
- (d) 2 only

40. Match List I with List II and select the correct answer using the code given below the lists :

<i>List I</i> (Type of work)	<i>List II</i> (Manufacturing)
A. High rate production of worm gears and worm wheel	1. Gear shaving
B. Generating internal gears and cluster gears	2. Gear milling
C. Finishing of gear tooth profiles	3. Gear hobbing
D. Repair and piece production of gears	4. Gear shaping

**Code :**

	A	B	C	D
(a)	2	1	4	3
(b)	3	1	4	2
(c)	2	4	1	3
(d)	3	4	1	2

41. Consider the following statements :

Helical gears may be designed in applications where gears are to be mounted on

1. Non-parallel shafts.
2. Parallel shafts.
3. Intersecting shafts.
4. Non-parallel and non-intersecting shafts.

Which of the above statements is/are correct ?

- (a) 1, 2 and 3 only
- (b) 1, 2, 3 and 4
- (c) 1 only
- (d) 2 and 4 only

42. For producing both internal and external screw threads, the method used is

- (a) Thread chasing with multiple-rib chasers
- (b) Thread milling with multiple-thread cutters
- (c) Thread tapping with taps
- (d) Die threading with self-opening die heads

43. In turning a solid round bar, if the travel of the cutting tool in the direction of feed motion is 1000 mm, rotational speed of the workpiece is 500 rpm, and rate of feed is 0.2 mm/revolution, then the machining time will be

- (a) 10 seconds
- (b) 100 seconds
- (c) 5 minutes
- (d) 10 minutes

44.

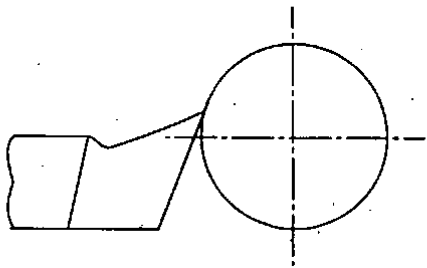

The effect of centering error when the tool is set above the center line as shown in the figure results effectively in

1. Increase in rake angle.
2. Reduction in rake angle.
3. Increase in clearance angle.
4. Reduction in clearance angle.

Which of these statements is/are correct ?

- (a) 1 only
- (b) 1 and 4 only
- (c) 2 and 4 only
- (d) 1, 2, 3 and 4

45. If the principal stresses and maximum shearing stresses are of equal numerical value at a point in a stressed body, the state of stress can be termed as

- (a) Isotropic
- (b) Uniaxial
- (c) Pure shear
- (d) Generalized plane state of stress

46. Consider the following statements :

In an orthogonal, single-point metal cutting, as the side-cutting edge angle is increased,

1. The tangential force increases.
2. The longitudinal force drops.
3. The radial force increases.

Which of these statements are correct ?

- (a) 1 and 3 only
- (b) 1 and 2 only
- (c) 2 and 3 only
- (d) 1, 2 and 3

47. In the Kendall's notation for representing queuing models the first position represents

- (a) Probability law for the arrival
- (b) Probability law for the service
- (c) Number of channels
- (d) Capacity of the system

48. Consider the following statements regarding annealing process :

1. All structural imperfections are removed.
2. The hypoeutectoid steel is heated to about  $50 - 70^{\circ}\text{C}$  below upper critical temperature.
3. Cooling can be done in heat treating furnace, by heating it, keeping the metal in it and turning off furnace till it cools to room temperature.
4. Uniform grain structure is resulted.

Which of these statements are correct ?

- (a) 1, 2 and 3 only
- (b) 2, 3 and 4 only
- (c) 1, 3 and 4 only
- (d) 1, 2, 3 and 4

49. Weldability of ferritic stainless steel used in automotive exhaust system is improved by selecting stainless steel electrode having low content of

- (a) Carbon
- (b) Nitrogen
- (c) Chromium
- (d) Carbon and Nitrogen

50. In assignment problem for variable  $x_{ij}$  :

1.  $x_{ij} = 1$  or 0

2.  $\sum_{j=1}^n x_{ij} = 1$

3.  $\sum_{i=1}^n x_{ij} = 1$

Which of these are correct ?

- (a) 1, 2 and 3
- (b) 2 and 3 only
- (c) 1 and 2 only
- (d) 1 and 3 only

51. Consider the following statements :

Use of functions

- 1. Helps to avoid repeating a set of statements many times.
- 2. Enhances the logical clarity of the program.
- 3. Makes the debugging task easier.

Which of the above statements is/are correct ?

- (a) 1 only
- (b) 2 and 3 only
- (c) 1 and 3 only
- (d) 1, 2 and 3

52. The overall transfer function of a closed loop automatic control system is equal to  $1 - \frac{1}{s}$ . If the transfer function of the feedback path is unity, the transfer function of the forward path is

- (a)  $s$
- (b)  $s + 1$
- (c)  $s - 1$
- (d)  $1 - s$

53. The hardness of lathe bed material should be measured by

- (a) Rockwell tester
- (b) Brinell hardness tester
- (c) Shore Scleroscope
- (d) Vickers hardness tester

54. Consider the following parts :

- 1. Grinding wheel
- 2. Brake lining
- 3. Self-lubricating bearings

Which of these parts are made by powder metallurgy technique ?

- (a) 1, 2 and 3
- (b) 2 only
- (c) 2 and 3 only
- (d) 1 and 2 only

55. Pearlite phase in an iron-carbide phase diagram is

- (a) Eutectic phase
- (b) Hypoeutectic mixture
- (c) Eutectoidal mixture
- (d) Hypereutectic phase

56. The purpose of `getchar()` function in C language is to

- (a) Write a single character at a time
- (b) Read a single character at a time
- (c) Copy a single character at a time
- (d) Delete a single character at a time

57. The equation of motion for a single degree of freedom system with viscous damping is  $16\ddot{x} + 5\dot{x} + 4x = 0$ . The damping ratio of the system is
- $\frac{5}{64}$
  - $\frac{5}{16}$
  - $\frac{5}{4\sqrt{2}}$
  - $\frac{2}{5}$
58. The efficiency of a power screw is a function of
- Screw geometry.
  - Coefficient of friction.
  - Load on the screw.
- Which of these are correct ?
- 1, 2 and 3
  - 1 and 2 only
  - 2 and 3 only
  - 1 and 3 only
59. With increasing cutting velocity, the total time for machining a component
- Decreases
  - Increases
  - Remains unaffected
  - First decreases and then increases
60. The probability law that determines the fluctuations of fraction defective is
- Poisson
  - Normal
  - Binomial
  - Exponential
61. Consider the following :
- Crystal structure
  - Relative size
  - Chemical affinity
  - Valency
- Which of these factors govern relative solubility of two metals in each other in the solid state ?
- 1, 2 and 3 only
  - 2, 3 and 4 only
  - 1, 2 and 4 only
  - 1, 2, 3 and 4
62. The statement `printf ("%d", (a++));` of C programming language will print
- The current value of a
  - The value of a+1
  - Garbage
  - An error message
63. Tool life is affected mainly with
- Feed
  - Depth of cut
  - Coolant
  - Cutting speed
64. In a 4-cylinder 4-stroke inline IC engine the angle between two successive cranks should be  $180^\circ$ . But this rule is violated for cranks 2 and 3 (i.e. inner cranks) and the angle is made  $0^\circ$ . This is done to achieve primary force
- and secondary force balancing
  - and secondary couple balancing
  - primary and secondary couple balancing
  - secondary force and primary couple balancing

65. Consider the following statements :
1. It is wedged shape.
  2. Its width is tapered but thickness is uniform.
  3. It is subjected to tensile force.

Which of these characteristics of a cotter are correct ?

- (a) 1 and 3 only
- (b) 1 and 2 only
- (c) 2 and 3 only
- (d) 1, 2 and 3

66. Which one of the following statements is *not* correct for the TQC ?

- (a) It is about the product quality and quality of all business processes.
- (b) It is restricted to product quality.
- (c) It utilizes quality circles.
- (d) It utilizes zero defect programmes.

67. Consider the following statements :

Alloying elements are added to

1. Improve hardness and toughness.
2. Corrosion and oxidation resistance improvement.
3. Improve machinability and hardenability.
4. Increase weight and volume.

Which of the above statements are correct ?

- (a) 1, 2 and 3 only
- (b) 2, 3 and 4 only
- (c) 1, 2 and 4 only
- (d) 1, 2, 3 and 4

68. The lead time in material requirements planning is the time between

- (a) Floating the tender and receiving the quotations from the vendor
- (b) Floating the tender and placing the purchase order to the vendor
- (c) Floating the tender and receiving the material from the vendor
- (d) Issuing purchase order and receiving the material from the vendor

69. Flank wear occurs on the

- (a) Relief face of the tool
- (b) Rake face
- (c) Nose of the tool
- (d) Cutting edge

70. The output of the given program fragment is

```
Char * S1 = "Makeover";
Char * S2 = "Take";
* S2 = * S1;
Printf ("%S", S2);
```

- (a) Makeover Take
- (b) Make
- (c) Makeover
- (d) Error

71. Surface imperfections which separate two orientations that are mirror image of one another is called

- (a) Stacking fault
- (b) Grain boundary
- (c) Tilt boundary
- (d) Twinned boundary

72. In an inert gas welding process, the commonly used gas is
- Hydrogen
  - Oxygen
  - Helium or Argon
  - Krypton
73. An allotropic material has
- Fixed structure at all temperatures
  - Atoms distributed in random pattern
  - Different crystal structures at different temperatures
  - Fixed structure but random atom distribution
74. If the ratio of the length of a connecting rod to the crank radius increases then
- Primary unbalanced forces decrease
  - Primary unbalanced forces increase
  - Secondary unbalanced forces decrease
  - Secondary unbalanced forces increase
75. Consider the following :
- In a flow chart, terminal symbol indicates
- Beginning.
  - Ending.
  - Arithmetic calculations.
  - Pauses.
- Which of these statements is/are correct ?
- 2 only
  - 2, 3 and 4 only
  - 1, 2 and 4 only
  - 1, 2, 3 and 4
76. The following information is added in updating the inventory status file in MRP :
- Disbursement of inventory
  - Scrap reported for material
  - Order release
  - Material received
77. In arc welding, the arc length should be equal to
- 4.5 times the rod diameter
  - 3 times the rod diameter
  - 1.5 times the rod diameter
  - Rod diameter
78. EOQ is taken at the point where the cost of carrying equals the cost of
- Ordering the materials
  - The material
  - The safety stock
  - Both the material and the safety stock
79. The following is the general policy for A class items in ABC analysis :
- Very strict control.
  - Frequent review of their consumption.
  - Safety stock kept.
- Which of the above statements is/are correct ?
- 1 only
  - 1 and 2 only
  - 2 only
  - 1, 2 and 3
80. If the speed of the engine varies between 390 and 410 rpm in a cycle of operation, the coefficient of fluctuation of speed will be
- 0.01
  - 0.02
  - 0.04
  - 0.05

81. Consider the following statements :

MRP constitutes a set of techniques that use

1. Bill of material.
2. Inventory data.
3. Master production schedule.

Which of the above statements is/are correct ?

- (a) 1, 2 and 3
- (b) 1 and 3 only
- (c) 2 and 3 only
- (d) 1 only

82. The ratio between Oxygen and Acetylene gases for neutral flame in gas welding is

- (a) 2 : 1
- (b) 1 : 2
- (c) 1 : 1
- (d) 4 : 1

83. Consider the following statements regarding welded joints :

1. It is a permanent type of joint.
2. It is reliable and economical for pressure vessel construction.
3. It is free from fabrication residual stresses.
4. Such joints are suitable for static loading only.
5. Welding is a versatile and flexible metal joining process.

Which of the above statements are correct ?

- (a) 1, 2 and 3 only
- (b) 2, 3 and 4 only
- (c) 1, 2, 3, 4 and 5
- (d) 1, 2 and 5 only

84. Consider the following statements :

The speed imbalance between memory access and CPU operation can be reduced by

1. Memory interleaving.
2. Reducing the size of memory.
3. Cache memory.

Which of the above statements is/are correct ?

- (a) 1 only
- (b) 2 only
- (c) 1 and 3 only
- (d) 1, 2 and 3

85. Consider the following advantages of shell mould casting :

1. Close dimensional tolerance.
2. Good surface finish.
3. Low cost.
4. Easier.

Which of these are correct ?

- (a) 1, 2 and 3 only
- (b) 2, 3 and 4 only
- (c) 1, 2 and 4 only
- (d) 1, 2, 3 and 4

86.

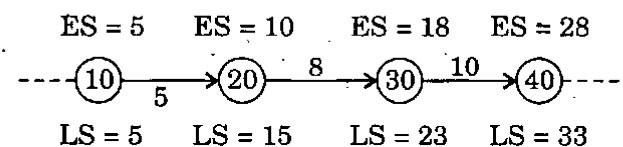

Consider the 3 activities of a CPM network as shown above. Earliest and latest occurrence times of these events are given on the nodes. The total float on activity 20 - 30 is

- (a) 0
- (b) 2
- (c) 3
- (d) 5

87. Iron-carbon equilibrium diagram
- (a) correlates the microstructure and properties of steel and cast iron
  - (b) indicates the phase changes occurring during heating and cooling
  - (c) is made by plotting carbon percentage along X-axis and temperature along Y-axis
  - (d) All of the above

88. A shaft transmits 1000 kW of power at 100 rad/s. Then the torque transmitted in kNm is
- (a) 0.1
  - (b) 1.0
  - (c) 10.0
  - (d) 100.0

89. During the time study on a job, the representative time, the rating and allowances are observed to be 0.4 minutes, 120% and 10% of standard time respectively. The normal time and standard time, in minutes, are respectively
- (a) 0.48 and 0.533
  - (b) 0.533 and 0.48
  - (c) 0.6 and 0.66
  - (d) 0.7 and 0.8

90. Match List I with List II and select the correct answer using the code given below the lists :

<u>List I</u>	<u>List II</u>
A. Point of inflection	1. Strain energy
B. Shearing strain	2. Equation of bending
C. Section modulus	3. Equation of torsion
D. Modulus of resilience	4. Bending moment diagram

**Code :**

	A	B	C	D
(a)	1	3	2	4
(b)	4	3	2	1
(c)	1	2	3	4
(d)	4	2	3	1

91. In PERT and CPM network the dummy activity
- (a) consumes time
  - (b) consumes resources
  - (c) is used to preserve the logic
  - (d) is a real activity

92. For a proper design and longer gear life
- (a) Wear load must be more than dynamic load
  - (b) Wear load must be less than dynamic load
  - (c) Dynamic load must be more than endurance strength
  - (d) Wear load must be less than endurance strength



93. In a multiple-disc clutch, the axial intensity of pressure is not to exceed 0.2 MPa. The inner radius of the discs is 100 mm and is half the outer radius. The axial force per pair of contact surfaces in N is

- (a)  $2000 \pi$
- (b)  $3000 \pi$
- (c)  $4000 \pi$
- (d)  $6000 \pi$

94. Metallic powders can be produced by

- (a) Atomization
- (b) Pulverization
- (c) Electro-deposition process
- (d) All of the above

95. If the probability of an acceptance of a 1% defective lot is 0.95, then AOQ is

- (a) 0.01
- (b) 0.10
- (c) 0.0095
- (d) 0.095

96. The leaving basic variable in simplex method is the basic variable that

- (a) has the lowest value
- (b) has the largest coefficient in the key row
- (c) has the smallest coefficient in the key row
- (d) goes to zero first as the entering basic variable is increased

97. Consider the following statements :

The material properties which principally determine how well a metal may be drawn are

1. Ratio of yield stress to ultimate stress.
2. Rate of increase of yield stress relative to progressive amounts of cold work.
3. Rate of work hardening.

Which of the above statements is/are correct ?

- (a) 1 and 2 only
- (b) 2 and 3 only
- (c) 1 only
- (d) 1, 2 and 3

98. Consider the following statements :

1. Resource limitations must be known.
2. Relationship of variables must be known.

Which of these statements must be satisfied to deal with the graphical techniques of linear programming effectively ?

- (a) 1 only
- (b) 2 only
- (c) Both 1 and 2
- (d) Neither 1 nor 2

99. Hydrodynamic bearings are preferred over rolling element bearings in some applications in which

- (a) Power losses are minimum
- (b) Higher loads are to be carried at relatively high speed
- (c) Higher loads are to be carried at relatively low speed
- (d) They are available 'off the shelf' in the market

100. Which one of the following statements is *not* correct ?

- (a) PERT is probabilistic whereas CPM is deterministic.
- (b) In PERT slack on various events is calculated whereas in CPM floats are calculated.
- (c) Critical path in a network is the path on which events have no slack.
- (d) More than four dummy activities cannot be used in a PERT network.

**Directions :** Each of the next twenty (20) items consists of two statements, one labelled as the 'Assertion (A)' and the other as 'Reason (R)'. You are to examine these two statements carefully and select the answers to these items using the codes given below :

**Codes :**

- (a) Both A and R are individually true and R is the correct explanation of A
- (b) Both A and R are individually true but R is **not** the correct explanation of A
- (c) A is true but R is false
- (d) A is false but R is true

101. **Assertion (A) :** In damped vibration there is decrease in amplitude of vibration during each successive cycle.

**Reason (R) :** Damping force is proportional to the amplitude.

102. **Assertion (A) :** A cast iron specimen shall fail due to shear when subjected to a compressive load.

**Reason (R) :** Shear strength of cast iron in compression is more than half its compressive strength.

103. **Assertion (A) :** A plane state of stress always results in a plane state of strain.

**Reason (R) :** A uniaxial state of stress results in a three-dimensional state of strain.

104. **Assertion (A) :** Most of the materials exist in single crystal.

**Reason (R) :** Sugar is a single crystal material.

105. **Assertion (A) :** Polycrystalline material is stronger than ordinary one.

**Reason (R) :** Crystals in polycrystalline material have different orientations with respect to each other.

106. **Assertion (A) :** Natural crystals always contain defects.

**Reason (R) :** The defects may affect colour and can make a crystal a valuable gem.

107. **Assertion (A) :** Plastic deformation is a function of applied stress, temperature and strain rate.

**Reason (R) :** Plastic deformation is accompanied by changes in both the internal and external state of the material.

108. **Assertion (A) :** In the high energy rate forming method, the explosive forming has proved to be an excellent method of utilizing energy at high rate and utilizes both the high explosives and low explosives.

**Reason (R) :** The gas pressure and rate of detonation can be controlled for both types of explosives.

109. *Assertion (A)* : Pickling and washing of rolled rods is carried out before wire drawing.

*Reason (R)* : They lubricate the surface to reduce friction while drawing wires.

110. *Assertion (A)* : The investment casting is used for precision parts such as turbine plates, sewing machines etc.

*Reason (R)* : The investment castings have a good surface finish and are exact reproductions of the master pattern.

111. *Assertion (A)* : Oxidizing flame is used in gas welding to join medium carbon steels having high melting point.

*Reason (R)* : In gas welding, oxidizing flame produces the maximum temperature compared to neutral and reducing flame.

112. *Assertion (A)* : Straight polarity is always recommended for Carbon-electrode welding.

*Reason (R)* : Carbon arc is stable in straight polarity.

113. *Assertion (A)* : It is generally difficult to weld Aluminium parts by normal arc welding process.

*Reason (R)* : Hard and brittle Aluminium-oxide film is formed at the welded joints.

114. *Assertion (A)* : Splines are useful in situations where the connected component is required to move axially while transmitting torque.

*Reason (R)* : Splines are similar to number of keys provided on a circumference of the shaft.

115. *Assertion (A)* : In design of friction clutches the torque transmission capacity is predicted from the condition of uniform rate of wear of friction plate.

*Reason (R)* : With the use of hard materials for the friction lining these is always perfect geometrical fit between two surfaces and hence pressure distribution over the contact zone is not uniform.

116. *Assertion (A)* : A state of plane strain always results in plane stress conditions.

*Reason (R)* : A thin sheet of metal stretched in its own plane results in plane strain conditions.

117. *Assertion (A)* : Climb or down milling operation ensures smoother operation of the machine tool and longer tool life as compared to the conventional up milling operation.

*Reason (R)* : In climb or down milling operation, the rotational motion of the cutter as well as the feed motion of the work-piece are in the same direction, and the depth of cut is maximum at the entry point as the cutter engages the work-piece.

118. *Assertion (A)* : Longitudinal cutting motion of the tool and cross-wise feed motion of the job generates flat surfaces in planing process.

*Reason (R)* : Jobs used in planing machines are generally long and heavy compared to shaping.

119. *Assertion (A)* : Inert gas and bare electrode instead of flux coated electrode is used in the case of automatic TIG and MIG welding processes.

*Reason (R)* : Better protection is provided by a cloud of inert gas than the cover created by the flux.

120. *Assertion (A)* : Indirect addressing reduces the size of an assembly level program significantly.

*Reason (R)* : Indirect addressing enables pointer based computation in high level languages.

**SPACE FOR ROUGH WORK**

**SPACE FOR ROUGH WORK**

**SPACE FOR ROUGH WORK**

**SPACE FOR ROUGH WORK**